

LP5990 microSMD Evaluation Board

National Semiconductor
Application Note 1584
John Bowie
July 2007



Introduction

This board is designed to allow the evaluation of the LP5990 Low Voltage CMOS Regulator. Each board is pre-assembled and tested in the factory. The board contains the LP5990 in a 4 bump micro SMD, 0.4mm pitch package with input and output capacitors connected to GND. The LP5990 will provide a 1.8V regulated output from a low input voltage of 2.2V and can provide 200mA to an external load. The LP5990 is particularly suitable for powering digital circuits, where good transient behavior is required.

The LP5990 is designed to be stable with space saving 0402 capacitors as small as 1 μ F.

5.5V. Input connections should be kept reasonably short (<300mm) to minimize input inductance and ensure optimum transient performance. If longer leads are used, then it may be required to increase the input capacitor value to 2.2 μ F.

ON/OFF control of the LP5990 is provided on the evaluation board by a logic signal applied to the V_{EN} pin. A minimum of 0.95V is required to guarantee the device to be on and the device will be shutdown with V_{EN} set to 0.4V or less. If ON/OFF control is not required, the V_{EN} pin can be connected to V_{IN}.

The load should be connected from the V_{OUT} pin to GND.

The schematic and board layout are shown below:

Operation

The input voltage, applied between V_{IN} and GND should be at least 1.0V above the output voltage with a maximum of

Schematic Diagram

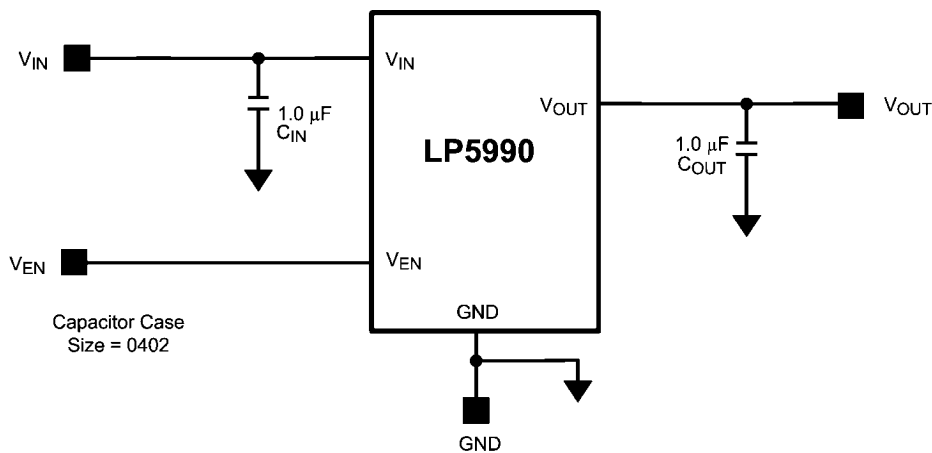

Evaluation Board Schematic

30009104

PCB Layout

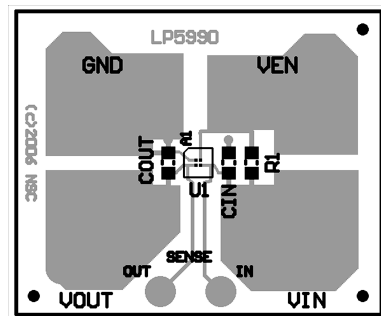

Evaluation Board Component and Pin Layout
Board Size:- 1.200" x 1.000"

30009105

Bill of Materials for LP5990 micro SMD Evaluation Board

Item	Value	Qty	Footprint	Note
U1	LP5990 TM-X.X	1	TMD-04	"X.X" corresponds to the output voltage option.
CIN	1.0 μ F	1	0402	X5R, Input Capacitor
COU	1.0 μ F	2	0402	X5R, Output Capacitor
R1	0 Ω	Not Fitted	0603	Connects V_{EN} to V_{IN}
Test Pins		6		

THE CONTENTS OF THIS DOCUMENT ARE PROVIDED IN CONNECTION WITH NATIONAL SEMICONDUCTOR CORPORATION ("NATIONAL") PRODUCTS. NATIONAL MAKES NO REPRESENTATIONS OR WARRANTIES WITH RESPECT TO THE ACCURACY OR COMPLETENESS OF THE CONTENTS OF THIS PUBLICATION AND RESERVES THE RIGHT TO MAKE CHANGES TO SPECIFICATIONS AND PRODUCT DESCRIPTIONS AT ANY TIME WITHOUT NOTICE. NO LICENSE, WHETHER EXPRESS, IMPLIED, ARISING BY ESTOPPEL OR OTHERWISE, TO ANY INTELLECTUAL PROPERTY RIGHTS IS GRANTED BY THIS DOCUMENT.

TESTING AND OTHER QUALITY CONTROLS ARE USED TO THE EXTENT NATIONAL DEEMS NECESSARY TO SUPPORT NATIONAL'S PRODUCT WARRANTY. EXCEPT WHERE MANDATED BY GOVERNMENT REQUIREMENTS, TESTING OF ALL PARAMETERS OF EACH PRODUCT IS NOT NECESSARILY PERFORMED. NATIONAL ASSUMES NO LIABILITY FOR APPLICATIONS ASSISTANCE OR BUYER PRODUCT DESIGN. BUYERS ARE RESPONSIBLE FOR THEIR PRODUCTS AND APPLICATIONS USING NATIONAL COMPONENTS. PRIOR TO USING OR DISTRIBUTING ANY PRODUCTS THAT INCLUDE NATIONAL COMPONENTS, BUYERS SHOULD PROVIDE ADEQUATE DESIGN, TESTING AND OPERATING SAFEGUARDS.

EXCEPT AS PROVIDED IN NATIONAL'S TERMS AND CONDITIONS OF SALE FOR SUCH PRODUCTS, NATIONAL ASSUMES NO LIABILITY WHATSOEVER, AND NATIONAL DISCLAIMS ANY EXPRESS OR IMPLIED WARRANTY RELATING TO THE SALE AND/OR USE OF NATIONAL PRODUCTS INCLUDING LIABILITY OR WARRANTIES RELATING TO FITNESS FOR A PARTICULAR PURPOSE, MERCHANTABILITY, OR INFRINGEMENT OF ANY PATENT, COPYRIGHT OR OTHER INTELLECTUAL PROPERTY RIGHT.

LIFE SUPPORT POLICY

NATIONAL'S PRODUCTS ARE NOT AUTHORIZED FOR USE AS CRITICAL COMPONENTS IN LIFE SUPPORT DEVICES OR SYSTEMS WITHOUT THE EXPRESS PRIOR WRITTEN APPROVAL OF THE CHIEF EXECUTIVE OFFICER AND GENERAL COUNSEL OF NATIONAL SEMICONDUCTOR CORPORATION. As used herein:

Life support devices or systems are devices which (a) are intended for surgical implant into the body, or (b) support or sustain life and whose failure to perform when properly used in accordance with instructions for use provided in the labeling can be reasonably expected to result in a significant injury to the user. A critical component is any component in a life support device or system whose failure to perform can be reasonably expected to cause the failure of the life support device or system or to affect its safety or effectiveness.

National Semiconductor and the National Semiconductor logo are registered trademarks of National Semiconductor Corporation. All other brand or product names may be trademarks or registered trademarks of their respective holders.

Copyright© 2007 National Semiconductor Corporation

For the most current product information visit us at www.national.com



National Semiconductor Americas Customer Support Center
 Email: new.feedback@nsc.com
 Tel: 1-800-272-9959

National Semiconductor Europe Customer Support Center
 Fax: +49 (0) 180-530-85-86
 Email: europe.support@nsc.com
 Deutsch Tel: +49 (0) 69 9508 6208
 English Tel: +49 (0) 870 24 0 2171
 Français Tel: +33 (0) 1 41 91 8790

National Semiconductor Asia Pacific Customer Support Center
 Email: ap.support@nsc.com

National Semiconductor Japan Customer Support Center
 Fax: 81-3-5639-7507
 Email: jpn.feedback@nsc.com
 Tel: 81-3-5639-7560