

LM5035A Evaluation Board

National Semiconductor
Application Note 1755
Steve Schulte
January 15, 2008



Introduction

The LM5035A evaluation board is designed to provide the design engineer with a fully functional power converter based on the Half Bridge topology to evaluate the LM5035A controller. The evaluation board is provided in an industry standard quarter-brick footprint.

The performance of the evaluation board is as follows:

- Input operating range: 36V to 75V
- Output voltage: 3.3V
- Output current: 0 to 30A
- Measured efficiency: 89% at 30A, 92% at 15A
- Frequency of operation: 400kHz
- Board size: 2.28 x 1.45 x 0.5 inches
- Load Regulation: 0.2%
- Line Regulation: 0.1%
- Line UVLO (33.9V/31.9V on/off)
- Line OVP (79.4V/78.3V off/on)
- Hiccup current limit

The printed circuit board consists of 6 layers; 2 ounce copper outer layers and 3 ounce copper inner layers on FR4 material with a total thickness of 0.062 inches. The unit is designed for continuous operation at rated load at 40°C and a minimum airflow of 200 CFM.

Theory of Operation

Power converters based on the Half Bridge topology offer high efficiency and good power handling capability in applications up to 500 Watts. The operation of the transformer causes the flux to swing in both directions, thereby better utilizing the magnetic core.

The Half Bridge converter is derived from the Buck topology family, employing separate high voltage (HO) and low voltage

(LO) modulating power switches with independent pulse width timing. The main difference between the topologies are, the Half Bridge topology employs a transformer to provide input / output ground isolation and a step down or step up function.

Each cycle, the main primary switch turns on and applies one-half the input voltage across the primary winding, which has 8 turns. The transformer secondary has 2 turns, leading to a 4:1 step-down of the input voltage. For an output voltage of 3.3V the composite duty cycle (D) of the primary switches varies from approximately 75% (low line) to 35% (high line).

The secondary employs synchronous rectification controlled by the LM5035A. During soft-start, the sync FET body diodes act as the secondary rectifiers until the main transformer energizes the gate drivers. The DLY resistor programs the non-overlap timing for the sync FETs to maximize efficiency while eliminating shoot through current.

Feedback from the output is processed by an amplifier and reference, generating an error voltage, which is coupled back to the primary side control through an optocoupler. The COMP input to the LM5035A greatly increases the achievable loop bandwidth. The capacitance effect (and associated pole) of the optocoupler is reduced by holding the voltage across the optocoupler constant. The LM5035A voltage mode controller pulse width modulates the error signal with a ramp signal derived from the line voltage (feedforwarding) to reduce the response time to input voltage changes. A standard "type III" network is used for the compensator.

The evaluation board can be synchronized to an external clock with a recommended frequency range of 420KHz to 500KHz.

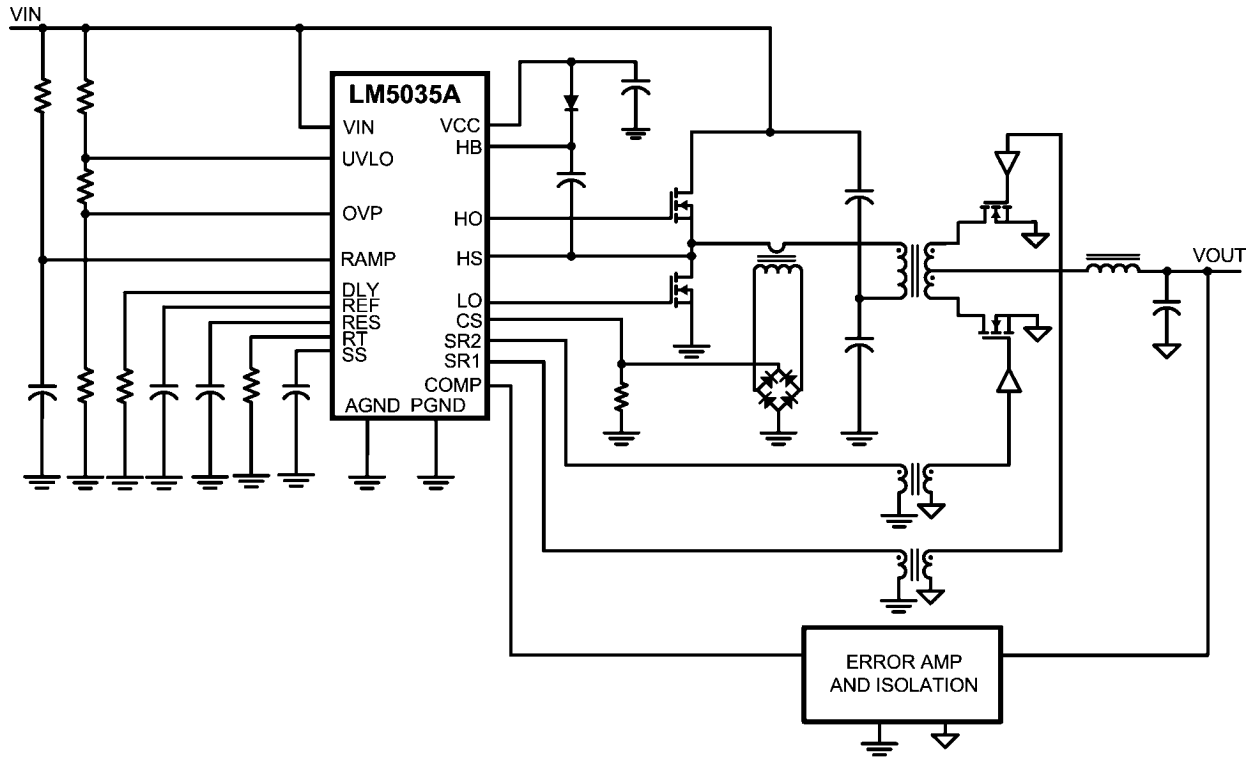

Simplified Half Bridge Converter

30044901

Powering and Loading Considerations

When applying power to the LM5035A evaluation board certain precautions need to be followed. A misconnection can damage the assembly.

Proper Connections

When operated at low input voltages the evaluation board can draw up to 3.5A of current at full load. The maximum rated output current is 30A. Be sure to choose the correct connector and wire size when attaching the source supply and the load. Monitor the current into and out of the evaluation board. Monitor the voltage directly at the output terminals of the evaluation board. The voltage drop across the load connecting wires will cause inaccurate measurements. This is especially true for accurate efficiency measurements.

Source Power

The evaluation board can be viewed as a constant power load. At low input line voltage (36V) the input current can reach 3.5A, while at high input line voltage (75V) the input current will be approximately 1.5A. Therefore, to fully test the LM5035A evaluation board a DC power supply capable of at least 85V and 5A is required.

The power supply must have adjustments for both voltage and current. The power supply and cabling must present low impedance to the evaluation board. Insufficient cabling or a high impedance power supply will cause voltage droop during turn-on due to the evaluation board inrush current. If large enough, this droop will cause a chattering condition upon power up. This chattering condition is an interaction with the evaluation board undervoltage lockout, the cabling impedance and the inrush current.

Loading

An appropriate electronic load, with specified operation down to 1.0V minimum, is desirable. The resistance of a maximum load is 0.11Ω. The high output current requires thick cables! If resistor banks are used there are certain precautions to be taken. The wattage and current ratings must be adequate for a 30A, 100W supply. Monitor both current and voltage at all times. Ensure there is sufficient cooling provided for the load.

Air Flow

Full power loading should never be attempted without providing the specified 200 CFM of air flow over the evaluation board. A stand-alone fan should be provided.

Powering Up

Using the ON/OFF pin (J2) provided will allow powering up the source supply with the current level set low. It is suggested that the load be kept low during the first power up. Set the current limit of the source supply to provide about 1.5 times the wattage of the load. As you remove the connection from the ON/OFF pin to ground (J1), immediately check for 3.3 volts at the output.

A most common occurrence, that will prove unnerving, is when the current limit set on the source supply is insufficient for the load. The result is similar to having the high source impedance referred to earlier. The interaction of the source supply folding back and the evaluation board going into undervoltage shutdown will start an oscillation, or chatter, that may have undesirable consequences.

A quick efficiency check is the best way to confirm that everything is operating properly. If something is amiss you can be reasonably sure that it will affect the efficiency adversely.

Few parameters can be incorrect in a switching power supply without creating losses and potentially damaging heat.

Over Current Protection

The evaluation board is configured with hiccup over-current protection. In the event of an output overload (approximately

35A) the unit will discharge the softstart capacitor, which disables the power stage. After a delay the softstart is released. The shutdown, delay and slow recharge time of the softstart capacitor protects the unit, especially during short circuit event where the stress is highest.

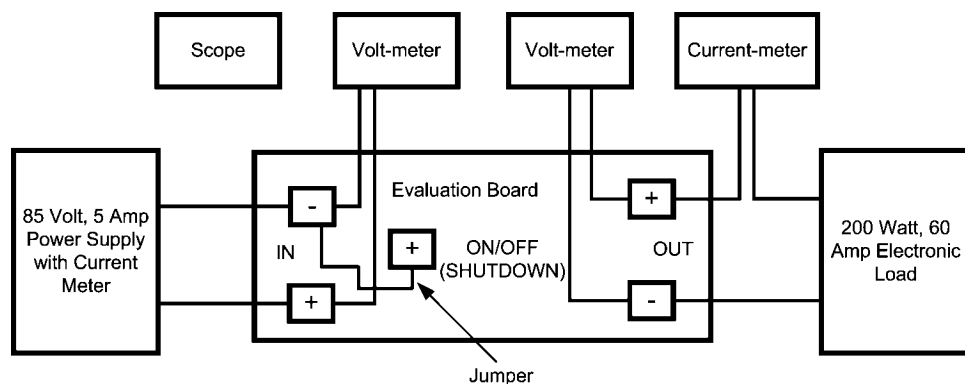

Typical Evaluation Setup

30044902

Performance Characteristics

TURN-ON WAVEFORMS

When applying power to the LM5035A evaluation board a certain sequence of events occurs. Soft-start capacitor values and other components allow for a minimal output voltage for a short time until the feedback loop can stabilize without overshoot. Figure 1 shows the output voltage during a typical start-up with a 48V input and a load of 5A. There is no overshoot during startup.

OUTPUT RIPPLE WAVEFORMS

Figure 2 shows the transient response for a load change from 15A to 22.5A. The upper trace shows minimal output voltage droop and overshoot during the sudden change in output current shown by the lower trace.

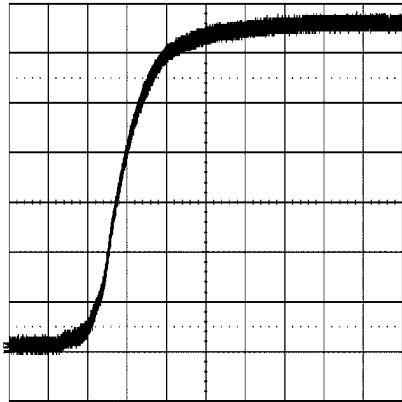

30044904

Conditions: Input Voltage = 48VDC
 Output Current = 5A
 Trace 1: Output Voltage Volts/div = 500mV
 Horizontal Resolution = 0.5ms/div

FIGURE 1.

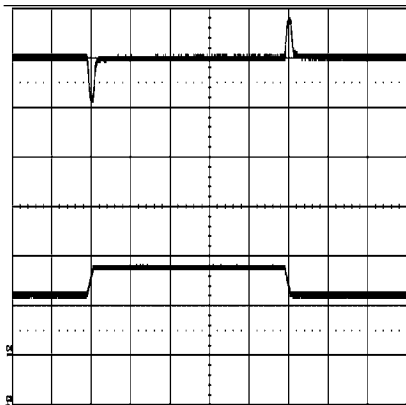

30044905

Conditions: Input Voltage = 48VDC
 Output Current = 15A to 22.5A
 Upper Trace: Output Voltage Volts/div = 50mV
 Lower Trace: Output Current = 15A to 22.5A to 15A
 Horizontal Resolution = 0.5ms/div

FIGURE 2.

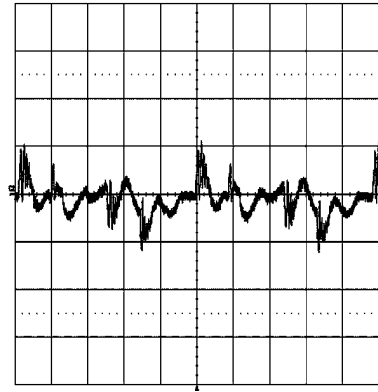

30044906

Conditions: Input Voltage = 48VDC
 Output Current = 30A
 Bandwidth Limit = 20MHz
 Trace 1: Output Ripple Voltage Volts/div = 20mV
 Horizontal Resolution = 1µs/div

FIGURE 3.

Figure 3 shows typical output ripple seen across the output terminals (with standard 10µF and 1µF ceramic capacitors) for an input voltage of 48V and a load of 30A. This waveform is typical of most loads and input voltages.

Figures 4 and 5 show the drain voltage of Q1 with a 5A load. Figure 4 represents an input voltage of 36V and Figure 5 represents an input voltage of 72V.

Figure 6 shows the gate voltages of the synchronous rectifiers. The deadtime provided by the 20kΩ DLY resistor is difficult to see at this timescale.

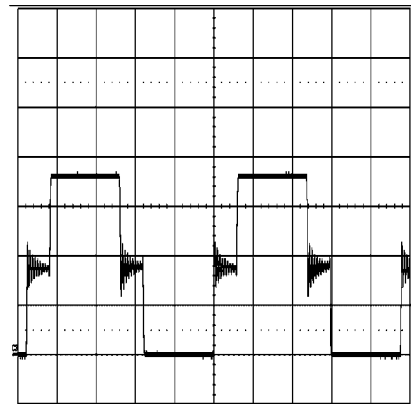

30044907

Conditions: Input Voltage = 36VDC
 Output Current = 5A
 Trace 1: Q1 drain voltage Volts/div = 10V
 Horizontal Resolution = 1µs/div

FIGURE 4.

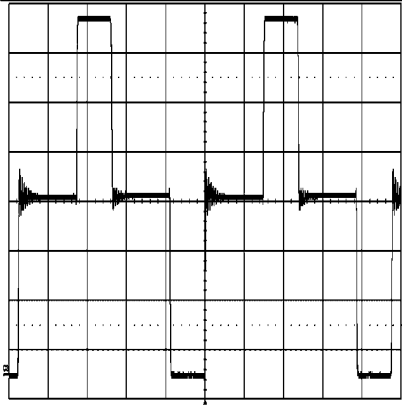

30044908

Conditions: Input Voltage = 72VDC
 Output Current = 5A
 Trace 1: Q2 drain voltage Volts/div = 10V
 Horizontal Resolution = 1 μ s/div

FIGURE 5.

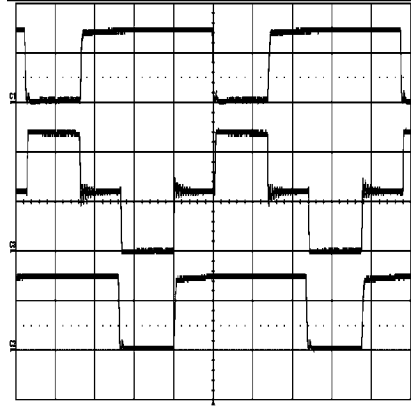

30044909

Conditions: Input Voltage = 48VDC
 Output Current = 5A
 Upper Trace: SR1, Q4 gate Volts/div = 5V
 Middle Trace: HS, Q2 drain Volts/div = 20V
 Lower Trace: SR2, Q6 gate Volts/div = 5V
 Horizontal Resolution = 1 μ s/div

FIGURE 6.

Application Circuit

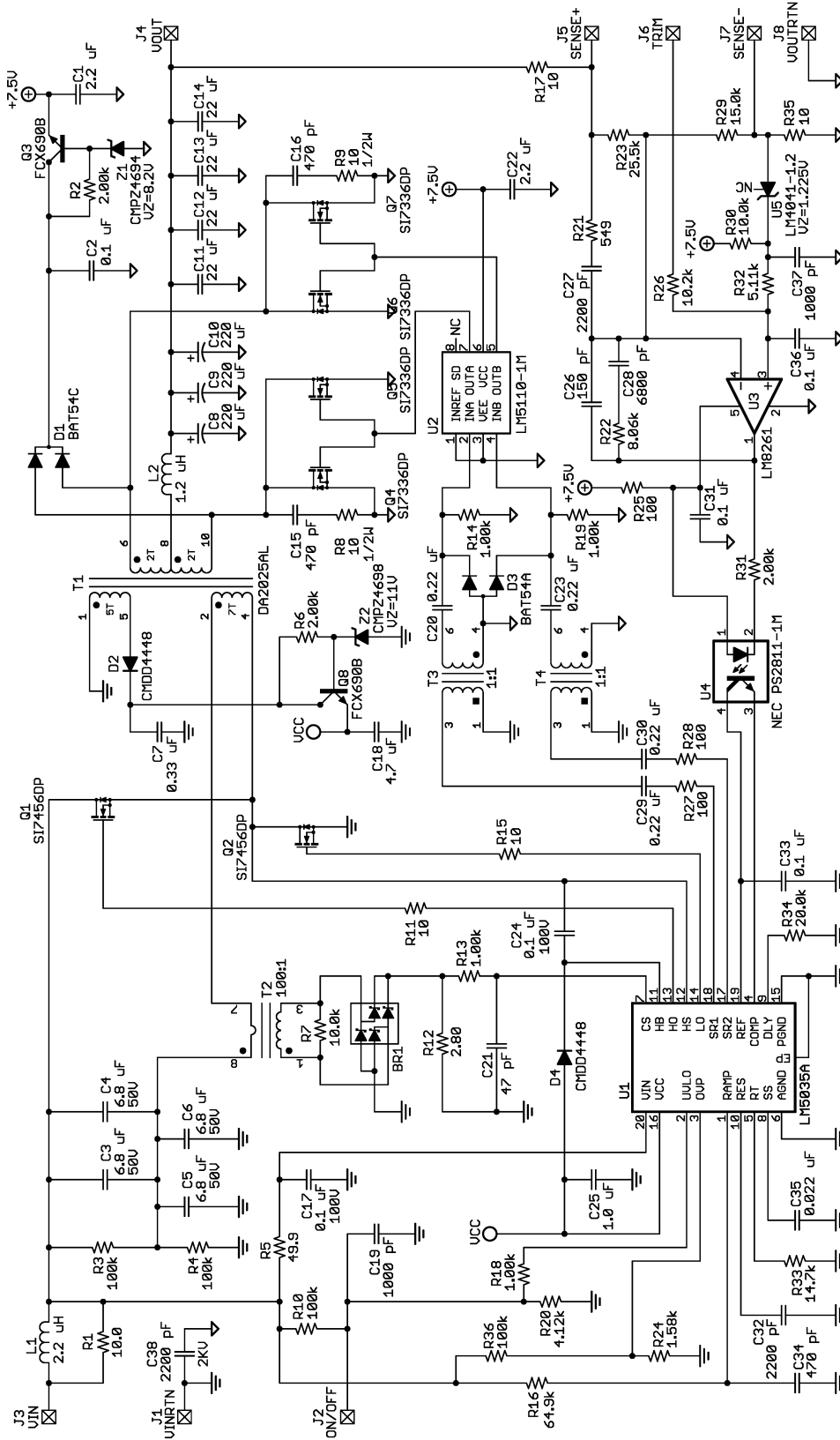

30044918

Application Circuit: Input 36 to 75V, Output 3.3V, 30A

DESIGNATOR	QTY	PART NUMBER	DESCRIPTION	VALUE
BR1	1	BAT54BRW	RECTIFIER, BRIDGE, DIODES INC	30V
C1,22	2	C2012X7R1C225K	CAPACITOR, 0805 X7R CER, TDK	2.2 μ , 16V
C2,31,33,36	4	C1608X7R1H104K	CAPACITOR, 0603 X7R CER, TDK	0.1 μ , 50V
C3 - 6	4	C4532X7R1H685M	CAPACITOR, 1812 X7R CER, TDK	6.8 μ , 50V
C7	1	C2012X7R1H334K	CAPACITOR, 0805 X7R CER, TDK	0.33 μ , 50V
C8 - 10	3	6TPE220MI	CAPACITOR, POSCAP, SANYO	220 μ , 6.3V
C11 - 14	4	C3216X5R0J226M	CAPACITOR, 1206 X5R CER, TDK	22 μ , 6.3V
C15, 16	2	C0805C471M5RAC	CAPACITOR, 0805 COG CER, KEMET	470p, 50V
C17, 24	2	C2012X7R2A104K	CAPACITOR, 0805 X7R CER, TDK	0.1 μ , 100V
C18	1	C3216X7R1C475K	CAPACITOR, 1206 X7R CER, TDK	4.7 μ , 16V
C19,37	2	C1608X7R1H102K	CAPACITOR, 0603 X7R CER, TDK	1000p, 50V
C20,23,29,30	4	C1608X7R1E224K	CAPACITOR, 0603 X7R CER, TDK	0.22 μ , 25V
C21	1	C1608C0G1H470J	CAPACITOR, 0603 X7R CER, TDK	47p, 50V
C25	1	C1608X7R1C105K	CAPACITOR, 0603 X7R CER, TDK	1.0 μ , 16V
C26	1	C1608C0G1H151J	CAPACITOR, 0603 COG CER, TDK	150p, 50V
C27,32	2	C1608C0G1H222J	CAPACITOR, 0603 COG CER, TDK	2200p, 50V
C28	1	C1608C0G 1H682J	CAPACITOR, 0603 COG CER, TDK	6800p, 50V
C35	1	C1608COG 1E223J	CAPACITOR, 0603 COG CER, TDK	0.022 μ , 25V
C34	1	C1608C0G1H471J	CAPACITOR, 0603 COG CER, TDK	470p, 50V
C38	1	C4532X7R3D222K	CAPACITOR, 1812 X7R CER, TDK	2200p, 2000V
D1	1	BAT54C	DIODE, SOT-23 SCHOTTKY, VISHAY	200mA, 30V
D2,4	2	CMDD4448	DIODE, SOD-323, CENTRAL SEMI	250mA, 75V
D3	1	BAT54A	DIODE, SOT-23 SCHOTTKY, VISHAY	200mA, 30V
L1	1	RLF7030T-2R2M5R4	INDUCTOR, TDK	2.2 μ H, 5.4A
L2	1	SER2010-122MX	INDUCTOR, COILCRAFT	1.2 μ H, 37A
Q1,2	2	SI7456DP	N-FET, SILICONIX	100V, 25m Ω
Q3,8	2	FCX690B	NPN, ZETEX	45V, 2A
Q4 - 7	4	SI7336ADP	N-FET, SILICONIX	30V, 3m Ω
R1,11,15	3	CRCW080510R0F	RESISTOR, 0805, VISHAY	10
R7,30	2	CRCW06031002F	RESISTOR, 0603, VISHAY	10k Ω
R2	1	CRCW08052001F	RESISTOR, 0805, VISHAY	2.00k Ω
R3,4	2	CRCW06031003F	RESISTOR, 0603, VISHAY	100k Ω
R5	1	CRCW080549R9F	RESISTOR, 0805, VISHAY	49.9 Ω
R6	1	CRCW08051002F	RESISTOR, 0805, VISHAY	10k Ω
R8,9	2	CRCW201010R0F	RESISTOR, 2010, VISHAY	10 Ω
R10,36	2	CRCW08051003F	RESISTOR, 0805, VISHAY	100k Ω
R16	1	CRCW08056492F	RESISTOR, 0805, VISHAY	64.9k Ω
R12	1	CRCW06032R80F	RESISTOR, 0603, VISHAY	2.8 Ω
R13,14,18,19	4	CRCW06031001F	RESISTOR, 0603, VISHAY	1k Ω
R17,35	2	CRCW060310R0F	RESISTOR, 0603, VISHAY	10 Ω
R20	1	CRCW06034121F	RESISTOR, 0603, VISHAY	4.12k Ω
R21	1	CRCW06035490F	RESISTOR, 0603, VISHAY	549 Ω
R22	1	CRCW06038061F	RESISTOR, 0603, VISHAY	8.06k Ω
R23	1	CRCW06032552F	RESISTOR, 0603, VISHAY	25.5k Ω
R24	1	CRCW06031581F	RESISTOR, 0603, VISHAY	1.58k Ω
R25,27,28	3	CRCW06031000F	RESISTOR, 0603, VISHAY	100 Ω
R26	1	CRCW06031022F	RESISTOR, 0603, VISHAY	10.2k Ω
R29	1	CRCW06031502F	RESISTOR, 0603, VISHAY	15k Ω

DESIGNATOR	QTY	PART NUMBER	DESCRIPTION	VALUE
R31	1	CRCW06032001F	RESISTOR, 0603, VISHAY	2.00k Ω
R32	1	CRCW06035111F	RESISTOR, 0603, VISHAY	5.11k Ω
R33	1	CRCW06031472F	RESISTOR, 0603, VISHAY	14.7k Ω
R34	1	CRCW06032002F	RESISTOR, 0603, VISHAY	20k Ω
T1	1	DA2025-AL	POWER XFR, COILCRAFT	8:5:2:2
T2	1	P8208	CURRENT XFR, PULSE ENG	100:1, 10A
T3,4	2	SM76924	GATE XFR, DATATRONIC	1:1
U1	1	LM5035AMH	CONTROLLER, NATIONAL SEMI	
U2	1	LM5110-1M	DRIVER, DUAL, NATIONAL SEMI	
U3	1	LM8261M5	OPAMP, SOT23-5, NATIONAL SEMI	
U4	1	PS2811-1M	OPTO-COUPLER, NEC	
U5	1	LM4041AIM3-1.2	REFERENCE, SOT23, NATIONAL SEMI	1.225V
Z1	1	CMPZ4694	ZENER, SOT23, CENTRAL SEMI	8.2V, 5%
Z2	1	CMPZ4698	ZENER, SOT23, CENTRAL SEMI	11V, 5%
J1,2,3,5,6,7	6	3104-2-00-01-00-00-08-0	0.040" PIN, MILL-MAX	
J4,8	2	3231-2-00-01-00-00-08-0	0.080" PIN, MILL-MAX	

PCB Layouts

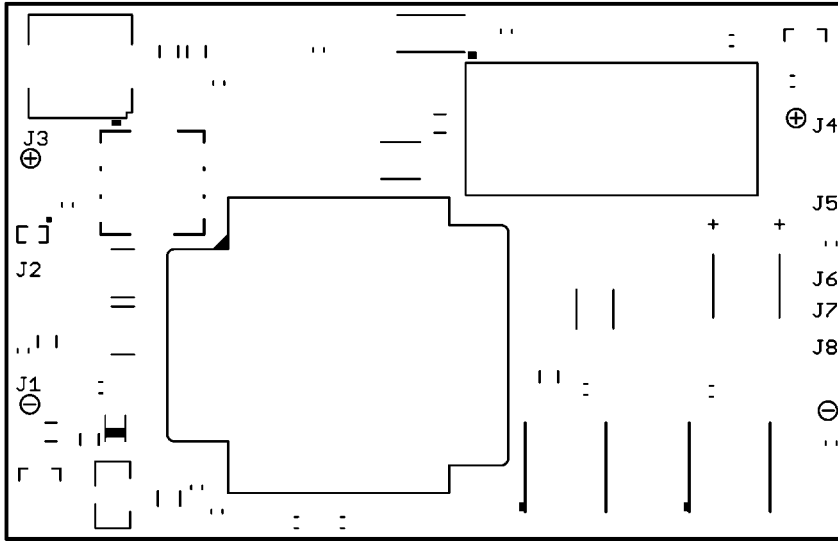

Top Side

30044910

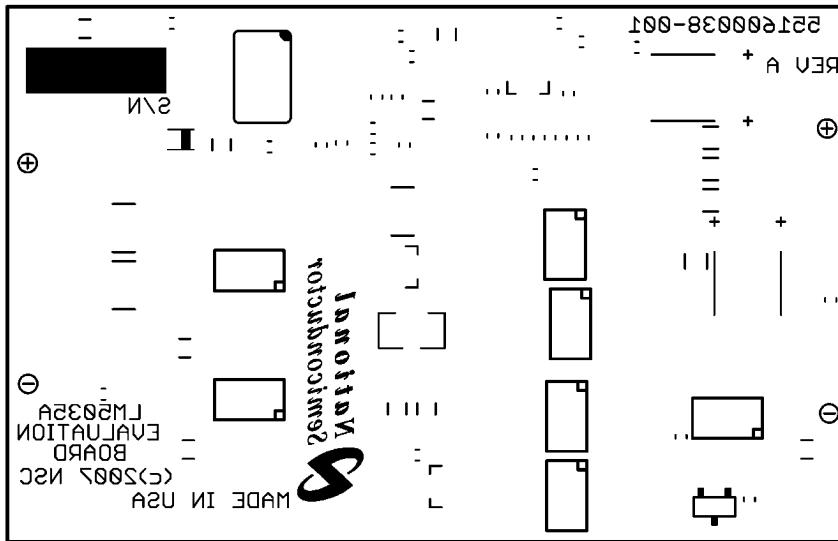

Bottom Side

30044911

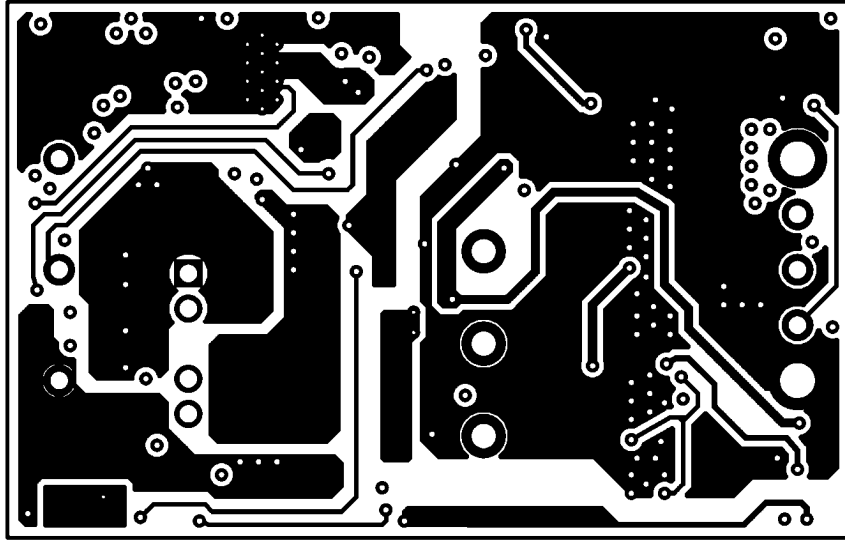

Layer 1

30044912

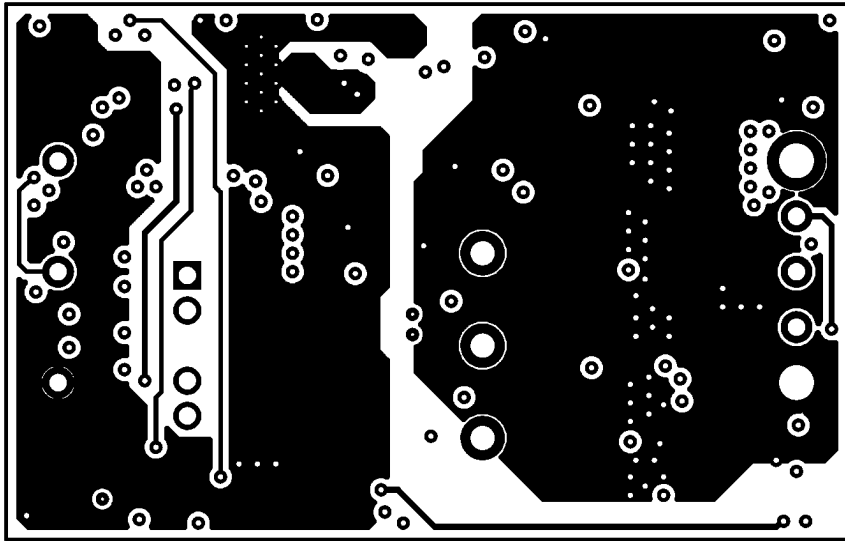

Layer 2

30044913

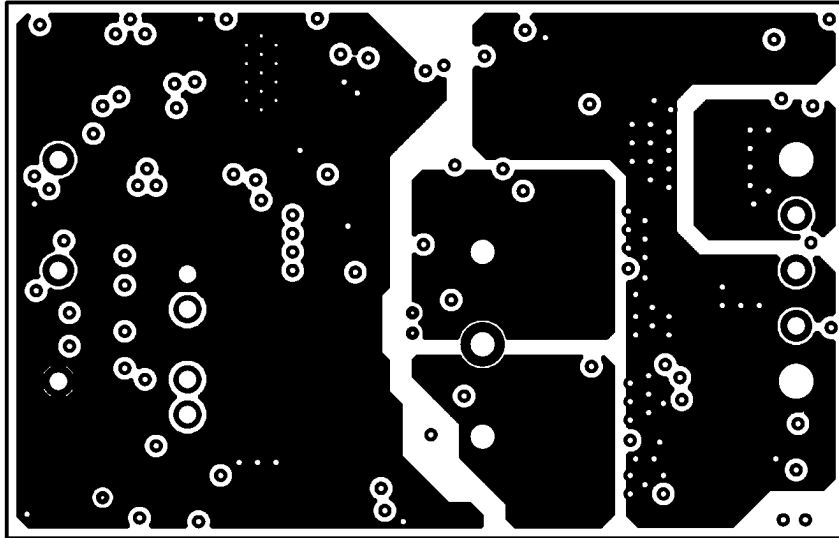

30044914

Layer 3

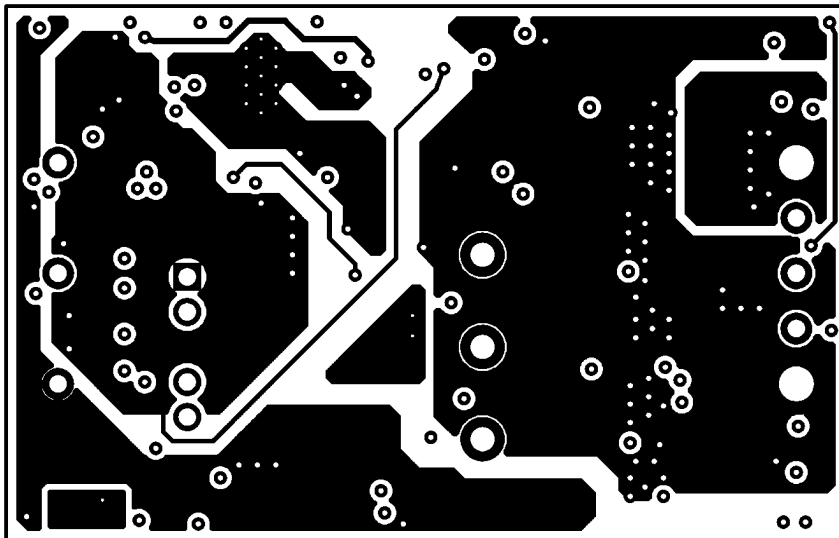

30044915

Layer 4

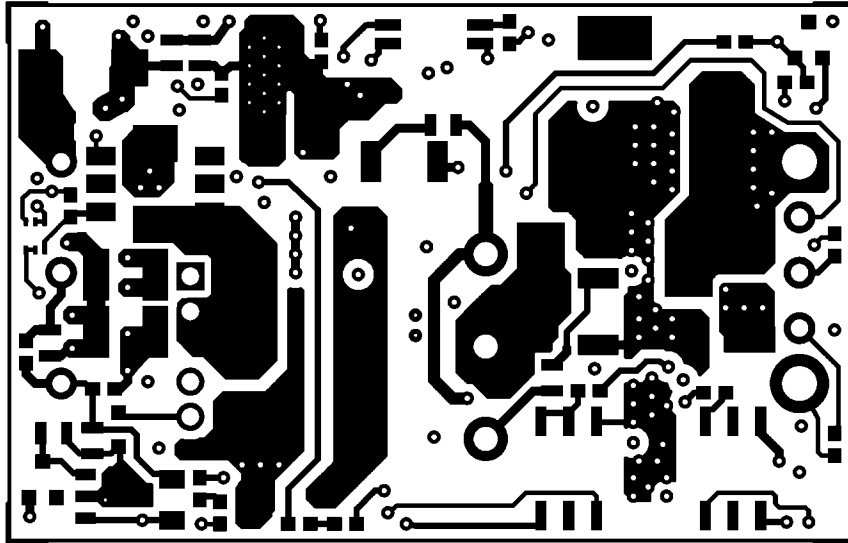

Layer 5

30044916

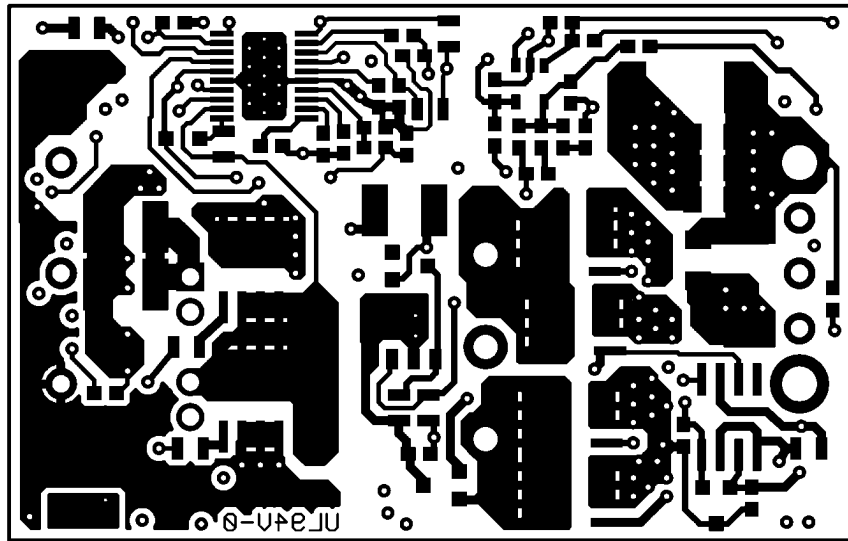

Layer 6

30044917

Notes

AN-1755

Notes

For more National Semiconductor product information and proven design tools, visit the following Web sites at:

Products		Design Support	
Amplifiers	www.national.com/amplifiers	WEBENCH	www.national.com/webench
Audio	www.national.com/audio	Analog University	www.national.com/AU
Clock Conditioners	www.national.com/timing	App Notes	www.national.com/appnotes
Data Converters	www.national.com/adc	Distributors	www.national.com/contacts
Displays	www.national.com/displays	Green Compliance	www.national.com/quality/green
Ethernet	www.national.com/ethernet	Packaging	www.national.com/packaging
Interface	www.national.com/interface	Quality and Reliability	www.national.com/quality
LVDS	www.national.com/lvds	Reference Designs	www.national.com/refdesigns
Power Management	www.national.com/power	Feedback	www.national.com/feedback
Switching Regulators	www.national.com/switchers		
LDOs	www.national.com/lido		
LED Lighting	www.national.com/led		
PowerWise	www.national.com/powerwise		
Serial Digital Interface (SDI)	www.national.com/sdi		
Temperature Sensors	www.national.com/tempsensors		
Wireless (PLL/VCO)	www.national.com/wireless		

THE CONTENTS OF THIS DOCUMENT ARE PROVIDED IN CONNECTION WITH NATIONAL SEMICONDUCTOR CORPORATION ("NATIONAL") PRODUCTS. NATIONAL MAKES NO REPRESENTATIONS OR WARRANTIES WITH RESPECT TO THE ACCURACY OR COMPLETENESS OF THE CONTENTS OF THIS PUBLICATION AND RESERVES THE RIGHT TO MAKE CHANGES TO SPECIFICATIONS AND PRODUCT DESCRIPTIONS AT ANY TIME WITHOUT NOTICE. NO LICENSE, WHETHER EXPRESS, IMPLIED, ARISING BY ESTOPPEL OR OTHERWISE, TO ANY INTELLECTUAL PROPERTY RIGHTS IS GRANTED BY THIS DOCUMENT.

TESTING AND OTHER QUALITY CONTROLS ARE USED TO THE EXTENT NATIONAL DEEMS NECESSARY TO SUPPORT NATIONAL'S PRODUCT WARRANTY. EXCEPT WHERE MANDATED BY GOVERNMENT REQUIREMENTS, TESTING OF ALL PARAMETERS OF EACH PRODUCT IS NOT NECESSARILY PERFORMED. NATIONAL ASSUMES NO LIABILITY FOR APPLICATIONS ASSISTANCE OR BUYER PRODUCT DESIGN. BUYERS ARE RESPONSIBLE FOR THEIR PRODUCTS AND APPLICATIONS USING NATIONAL COMPONENTS. PRIOR TO USING OR DISTRIBUTING ANY PRODUCTS THAT INCLUDE NATIONAL COMPONENTS, BUYERS SHOULD PROVIDE ADEQUATE DESIGN, TESTING AND OPERATING SAFEGUARDS.

EXCEPT AS PROVIDED IN NATIONAL'S TERMS AND CONDITIONS OF SALE FOR SUCH PRODUCTS, NATIONAL ASSUMES NO LIABILITY WHATSOEVER, AND NATIONAL DISCLAIMS ANY EXPRESS OR IMPLIED WARRANTY RELATING TO THE SALE AND/OR USE OF NATIONAL PRODUCTS INCLUDING LIABILITY OR WARRANTIES RELATING TO FITNESS FOR A PARTICULAR PURPOSE, MERCHANTABILITY, OR INFRINGEMENT OF ANY PATENT, COPYRIGHT OR OTHER INTELLECTUAL PROPERTY RIGHT.

LIFE SUPPORT POLICY

NATIONAL'S PRODUCTS ARE NOT AUTHORIZED FOR USE AS CRITICAL COMPONENTS IN LIFE SUPPORT DEVICES OR SYSTEMS WITHOUT THE EXPRESS PRIOR WRITTEN APPROVAL OF THE CHIEF EXECUTIVE OFFICER AND GENERAL COUNSEL OF NATIONAL SEMICONDUCTOR CORPORATION. As used herein:

Life support devices or systems are devices which (a) are intended for surgical implant into the body, or (b) support or sustain life and whose failure to perform when properly used in accordance with instructions for use provided in the labeling can be reasonably expected to result in a significant injury to the user. A critical component is any component in a life support device or system whose failure to perform can be reasonably expected to cause the failure of the life support device or system or to affect its safety or effectiveness.

National Semiconductor and the National Semiconductor logo are registered trademarks of National Semiconductor Corporation. All other brand or product names may be trademarks or registered trademarks of their respective holders.

Copyright© 2008 National Semiconductor Corporation

For the most current product information visit us at www.national.com



**National Semiconductor
Americas Technical
Support Center**
Email:
new.feedback@nsc.com
Tel: 1-800-272-9959

**National Semiconductor Europe
Technical Support Center**
Email: europe.support@nsc.com
German Tel: +49 (0) 180 5010 771
English Tel: +44 (0) 870 850 4288

**National Semiconductor Asia
Pacific Technical Support Center**
Email: ap.support@nsc.com

**National Semiconductor Japan
Technical Support Center**
Email: jpn.feedback@nsc.com