

LP38502SD-ADJ Evaluation Board

National Semiconductor
Application Note 1758
Chester Simpson
November 28, 2007



Introduction

The LP38502SD-ADJ is a 1.5A Low-Dropout (LDO) linear regulator in the LLP-8 package which has an adjustable output voltage (set by external resistors).

Basic Application Circuit

The basic application circuit which is built up on the evaluation board is shown in *Figure 1*:

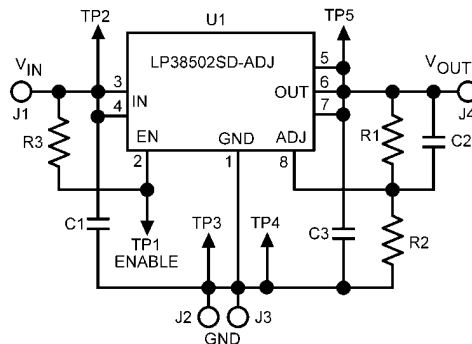

Basic Application Circuit

30045801

FIGURE 1.

Changing the Output Voltage

The resistors R1 and R2 set the output voltage. The equation to determine output voltage is:

$$V_{OUT} = V_{ADJ} \times (1 + R1/R2)$$

where V_{ADJ} is typically 0.6V.

The board has installed values of:

R1 = 19.1k Ω

R2 = 6.04k Ω

Which sets the output to 2.5V. R1 can be adjusted to change the nominal output voltage to other values. The minimum output voltage which can be set is the ADJ pin voltage, which is approximately 0.6V. This is obtained by installing a jumper or low value resistor (less than 10 Ω) at R1. The maximum usable output voltage is limited by the maximum input voltage which is 5.5V. Since rated dropout voltage at full current is 0.375V, this means the maximum usable output voltage for full current operation is about 5.1V.

Feedforward Capacitor C2

The PCB layout includes a location for C2, which is a feedforward capacitor connected across R1. If the data sheet guidelines are followed, and R2 does not exceed 10 k Ω , C2 is not required and has no effect on performance. The internal compensation is such that an internal zero provides more than adequate phase margin so external compensation is never needed.

However, if the value of R2 is increased above 10 k Ω , the effect of the internal zero gradually diminishes and the phase

margin is reduced. At an R2 value of approximately 50 k Ω , the phase margin will be low enough that instability may occur. In such cases, some of the lost phase margin can be regained by placing a capacitor at C2. Although it is sometimes possible to regain adequate phase margin this way, it is recommended that the data sheet guidelines be followed and R2 not exceed 10 k Ω (so C2 is never required).

Power Dissipation

The power dissipated within the regulator IC is given by:

$$P_D = I_L (V_{IN} - V_{OUT})$$

Where:

P_D is the power dissipated in the IC regulator U1.

I_L is the load current.

V_{IN} is the value of V_{IN} measured at TP2 (not at J1).

V_{OUT} is the value of V_{OUT} measured at TP5 (not at J4).

The thermal resistance of U1 from junction to ambient can be assumed to be approximately 80 $^{\circ}$ C/W for this assembly. That means that the junction temperature will rise about 80 $^{\circ}$ C above ambient for each Watt of power dissipated within the IC.

The parametric specifications of the IC are for a maximum junction temperature of 125 $^{\circ}$ C, and the maximum allowable junction temperature is 150 $^{\circ}$ C. **This limits maximum usable power dissipation for this package to approximately 1.5W.** If power dissipation exceeds this (and the junction temperature approaches 150 $^{\circ}$ C) the part may go into thermal shutdown.

PCB Component Layout

The components listed in the basic application circuit can be identified using the silkscreen on the top layer of the PCB (see Figure 2):

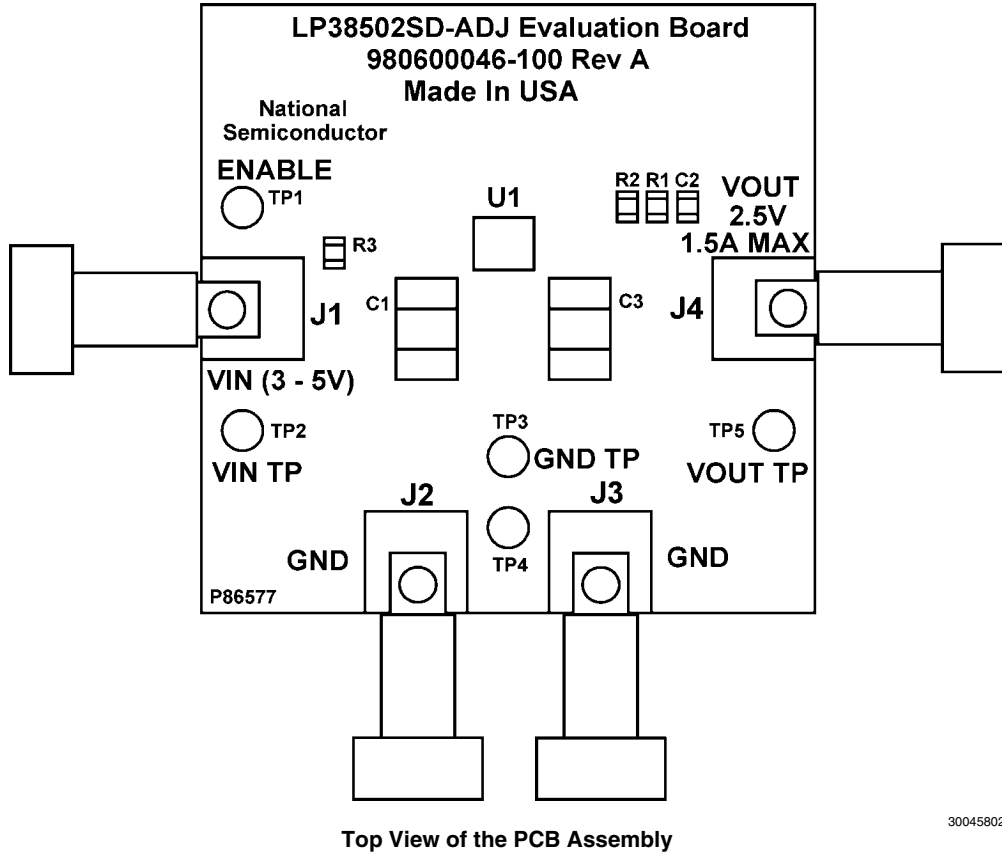

30045802

FIGURE 2.

Bill of Materials

The initial evaluation boards were built up for a 2.5V regulated output. The components used in the PCB assembly are listed below:

Designator	Qty.	Description	Part Number
PCB	1	PC board	551600046-001
R1	1	Resistor, 19.1kΩ, 1%	Vishay CRCW08051912F
R2	1	Resistor, 6.04kΩ, 1%	Vishay CRCW08056041F
R3	1	Resistor, 51.1kΩ, 1%	Vishay CRCW08055112F
J1	1	Red Banana Jack	Digi-Key J-151-ND
J2,J3	2	Black Banana Jack	Digi-Key J-152-ND
J4	1	Blue Banana Jack	Digi-Key J-155-ND
C1,C3	2	Cap, CER, 10 μF	Digi-Key PCC2225CT-ND
TP1-TP5	5	Test Points	Newark 160-2043-02-01-00
U1	1	IC, LP38502SD-ADJ	LP38502SD-ADJ
C2		****NOT INSTALLED FOR THIS ASSEMBLY	

Notes

For more National Semiconductor product information and proven design tools, visit the following Web sites at:

Products		Design Support	
Amplifiers	www.national.com/amplifiers	WEBENCH	www.national.com/webench
Audio	www.national.com/audio	Analog University	www.national.com/AU
Clock Conditioners	www.national.com/timing	App Notes	www.national.com/appnotes
Data Converters	www.national.com/adc	Distributors	www.national.com/contacts
Displays	www.national.com/displays	Green Compliance	www.national.com/quality/green
Ethernet	www.national.com/ethernet	Packaging	www.national.com/packaging
Interface	www.national.com/interface	Quality and Reliability	www.national.com/quality
LVDS	www.national.com/lvds	Reference Designs	www.national.com/refdesigns
Power Management	www.national.com/power	Feedback	www.national.com/feedback
Switching Regulators	www.national.com/switchers		
LDOs	www.national.com/ldo		
LED Lighting	www.national.com/led		
PowerWise	www.national.com/powerwise		
Serial Digital Interface (SDI)	www.national.com/sdi		
Temperature Sensors	www.national.com/tempsensors		
Wireless (PLL/VCO)	www.national.com/wireless		

THE CONTENTS OF THIS DOCUMENT ARE PROVIDED IN CONNECTION WITH NATIONAL SEMICONDUCTOR CORPORATION ("NATIONAL") PRODUCTS. NATIONAL MAKES NO REPRESENTATIONS OR WARRANTIES WITH RESPECT TO THE ACCURACY OR COMPLETENESS OF THE CONTENTS OF THIS PUBLICATION AND RESERVES THE RIGHT TO MAKE CHANGES TO SPECIFICATIONS AND PRODUCT DESCRIPTIONS AT ANY TIME WITHOUT NOTICE. NO LICENSE, WHETHER EXPRESS, IMPLIED, ARISING BY ESTOPPEL OR OTHERWISE, TO ANY INTELLECTUAL PROPERTY RIGHTS IS GRANTED BY THIS DOCUMENT.

TESTING AND OTHER QUALITY CONTROLS ARE USED TO THE EXTENT NATIONAL DEEMS NECESSARY TO SUPPORT NATIONAL'S PRODUCT WARRANTY. EXCEPT WHERE MANDATED BY GOVERNMENT REQUIREMENTS, TESTING OF ALL PARAMETERS OF EACH PRODUCT IS NOT NECESSARILY PERFORMED. NATIONAL ASSUMES NO LIABILITY FOR APPLICATIONS ASSISTANCE OR BUYER PRODUCT DESIGN. BUYERS ARE RESPONSIBLE FOR THEIR PRODUCTS AND APPLICATIONS USING NATIONAL COMPONENTS. PRIOR TO USING OR DISTRIBUTING ANY PRODUCTS THAT INCLUDE NATIONAL COMPONENTS, BUYERS SHOULD PROVIDE ADEQUATE DESIGN, TESTING AND OPERATING SAFEGUARDS.

EXCEPT AS PROVIDED IN NATIONAL'S TERMS AND CONDITIONS OF SALE FOR SUCH PRODUCTS, NATIONAL ASSUMES NO LIABILITY WHATSOEVER, AND NATIONAL DISCLAIMS ANY EXPRESS OR IMPLIED WARRANTY RELATING TO THE SALE AND/OR USE OF NATIONAL PRODUCTS INCLUDING LIABILITY OR WARRANTIES RELATING TO FITNESS FOR A PARTICULAR PURPOSE, MERCHANTABILITY, OR INFRINGEMENT OF ANY PATENT, COPYRIGHT OR OTHER INTELLECTUAL PROPERTY RIGHT.

LIFE SUPPORT POLICY

NATIONAL'S PRODUCTS ARE NOT AUTHORIZED FOR USE AS CRITICAL COMPONENTS IN LIFE SUPPORT DEVICES OR SYSTEMS WITHOUT THE EXPRESS PRIOR WRITTEN APPROVAL OF THE CHIEF EXECUTIVE OFFICER AND GENERAL COUNSEL OF NATIONAL SEMICONDUCTOR CORPORATION. As used herein:

Life support devices or systems are devices which (a) are intended for surgical implant into the body, or (b) support or sustain life and whose failure to perform when properly used in accordance with instructions for use provided in the labeling can be reasonably expected to result in a significant injury to the user. A critical component is any component in a life support device or system whose failure to perform can be reasonably expected to cause the failure of the life support device or system or to affect its safety or effectiveness.

National Semiconductor and the National Semiconductor logo are registered trademarks of National Semiconductor Corporation. All other brand or product names may be trademarks or registered trademarks of their respective holders.

Copyright© 2007 National Semiconductor Corporation

For the most current product information visit us at www.national.com



**National Semiconductor
Americas Customer
Support Center**
Email:
new.feedback@nsc.com
Tel: 1-800-272-9959

**National Semiconductor Europe
Customer Support Center**
Fax: +49 (0) 180-530-85-86
Email: europe.support@nsc.com
Deutsch Tel: +49 (0) 69 9508 6208
English Tel: +49 (0) 870 24 0 2171
Français Tel: +33 (0) 1 41 91 8790

**National Semiconductor Asia
Pacific Customer Support Center**
Email: ap.support@nsc.com

**National Semiconductor Japan
Customer Support Center**
Fax: 81-3-5639-7507
Email: jpn.feedback@nsc.com
Tel: 81-3-5639-7560